

**SOUND
MAGUS**

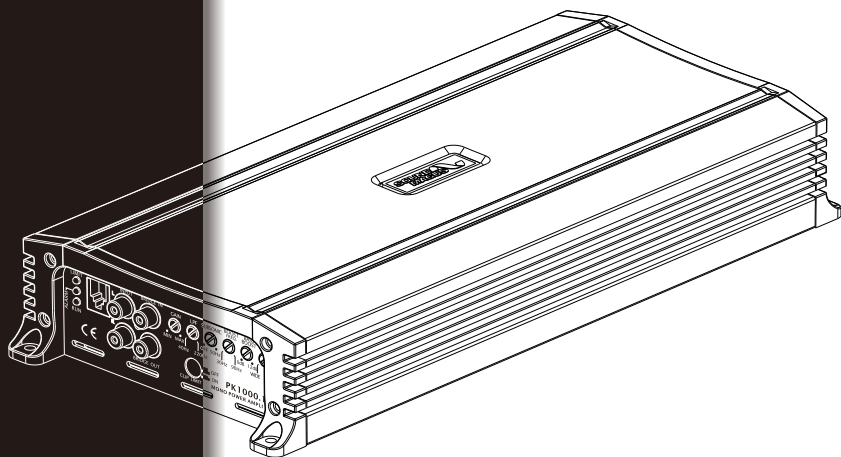

PK600.1M / PK1000.1M

PK700.4M / PK1400.4M

OWNERS MANUAL

INTRODUCTION

Congratulations on purchasing your SOUNDMAGUS amplifier. Please read this manual in order to fully understand how to get the best results from this product and ensure that all advice on how to look after the product is followed.

Thank you for buying SOUNDMAGUS, we hope you enjoy listening to your product as much as we enjoyed creating it.



ATTENTION

An aftermarket audio amplifier will place an additional load on the vehicles charging system.

Most modern vehicles have sufficient capacity in the charging system as not all the electrical components of the vehicle will be switched on at once.

Check the fuse rating of the amplifier and use this as the peak current requirement.

Generally the continuous current draw will be a third of the peak current.

FEATURES

- High efficiency, Energy-saving digital automotive amplifier
- High Power Type, Compact Products
- MCU Power Management (PK700.4M/PK1400.4M only)
- High / Low Level Input Switch (PK700.4M/PK1400.4M only)
- Auto Turn - on / off Functions (PK700.4M/PK1400.4M only)
- High Reliability Full Mosfet Design
- High Pass / Low Pass Filter And Subsonic Adjustable
- Bassboost frequency and level adjustable
- Clip limit function and Q factor adjustable
- Overload, shortcircuit, thermal, low voltage protection
- Rohs Compliant

PANEL LAYOUT

PK600.1M/PK1000.1M

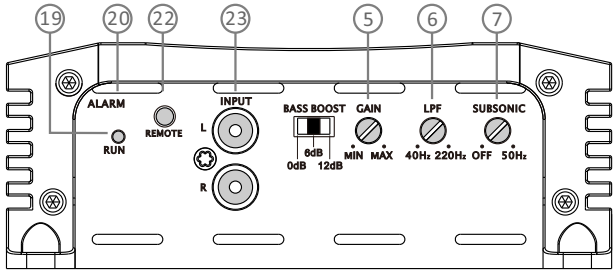
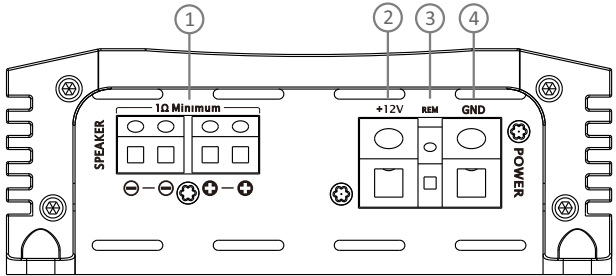

PK600.1M

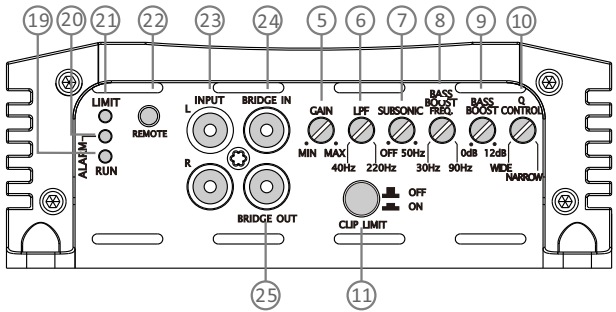

PK1000.1M

1. SPEAKERS

Connect speakers/subwoofers to these terminals. Be sure to check wire for proper polarity. Never connect the speaker cables to chassis ground.

2. +12 Volt Power

Connect this terminal through a FUSE or CIRCUIT BREAKER to the positive terminal of the vehicle battery or the positive terminal of an isolated audio system battery.

Warning: Always protect this power cable by installing a fuse or circuit breaker of the appropriate size within 18 inches (45cm) of the battery terminal connection.

3. Remote Turn On

This terminal turns on the amplifier when (+)12 volt is applied to it . Connect it to the remote turn on lead of the head unit or signal source.

CONTROL FUNCTIONS

4. GND

Connect this cable directly to the frame of the vehicle. Make sure the metal frame has been stripped of all paint down to the bare metal. Use the shortest distance possible. It is always a good idea to replace the factory ground at this time with a larger cable equal to the new amplifier power cable or larger.

CAUTION: Do not connect this terminal directly to the vehicle battery ground terminal or any other factory ground points.

5. GAIN

The level control will match the amplifiers sensitivity to the source units signal voltage. The Operating range is 200mV minimum to 5V maximum. This is NOT a volume control!

6. LPF

This control is used to select the desired low pass x-over frequency. The frequency can be adjusted from 40Hz to 220Hz for all bass mono models.

7. Subsonic Filter Control

This control can filter out unwanted low frequency from 10Hz (OFF) to 50Hz. This function will increase the power handling of your woofers.

8. Bass Boost Frequency

By adjusting these two knobs, you can boost a wanted frequency to a wanted level. The center boost frequency is adjustable from 30Hz to 90Hz,

9. BASSBOOST

This knob adjust the boost level of the bassboost center frequency. It can be adjusted from 0 to 12dB. Combining with bassboost frequency, you can accurately match the amplifier performance to woofer response.

10. Q-Control

This knob adjust the curve shape of bassboost. Turn it to narrow side will make the boosted frequency narrow and sharp, turn it to wide will extend the boosted frequency range. Combining with bassboost frequency and bassboost level adjusting, you can get a perfect bass response matching your system.

11. CLIP LIMIT Switch

This switch control the output clip limit on/off. When switched on, the amplifier will control the output level at clip point and reduce the distortion. This will keep your amplifier at a low distortion at clipped signal.

12. X-over mode and frequency Control (Only PK1400.4M)

These controls allow control over the frequencies played for PK1400.4M. There is an option for Low Pass, Full Range or High Pass. In LP mode the frequency range is from 50Hz to 200Hz (PK1400.4M is from 50Hz to 750Hz), In HP mode the frequency range is from 15Hz to 200Hz.

13. Bass Boost Frequency and Level Control

By adjusting these two knobs, you can boost a wanted frequency to a wanted level. The center boost frequency is adjustable from 30Hz to 90Hz, the boost level is adjustable from 0dB to 12dB.

14. HPF

This control is used to set the HPF crossover frequency for the front amplifier er channel. The frequency is adjustable between OFF and 200Hz.

PK700.4M/PK1400.4M

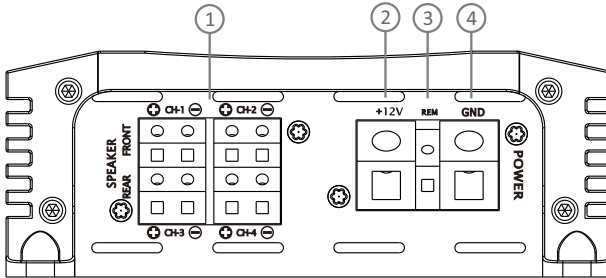

PK700.4M

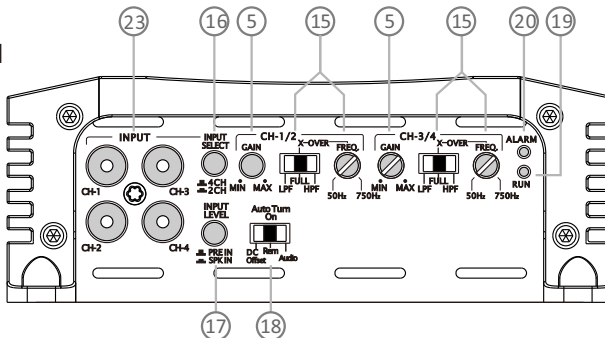

PK1400.4M

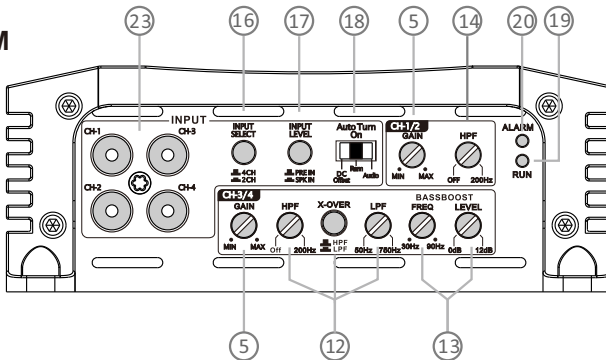

15. LPF/FULL/HPF selector & frequency adjustable knob

This switch and knob control Low Pass Filter, High Pass and Full pass function. When set to LPF, the amplifier will cut off high frequencies and should be used driving subwoofers. When set to HPF, the amplifier will cut off low frequencies and should be used driving full range speakers or tweeter. When set to Full, Full range of frequencies are reproduced and output to the speakers. In another words the filters are "OFF".

16. 4CH/2CH Switch(PK700.4M/PK1400.4M)

This knob switch 2ch/4ch input mode. When press in, Amplifier works at 2CH input mode, CH-B input will be paralleled to CH-A, CH-B input jack will be dummy. When pressed knob out, Amplifier will work at 4CH mode.

17. INPUT LEVEL(PK700.4M/PK1400.4M only)

The amplifier has dual input sensitivity differential inputs which will receive either High level (Speaker output) or Low level (RCA) signals from your car stereo's source unit.

When switch to PRE IN, The signal can be delivered to the amplifier using the low level RCA outputs on the source unit.

When switch to SPK IN, The high-level signal can be run from the source unit's speaker outputs to the stereo RCA input on the end panel of the amplifier using the HL01.

18. Auto Turn On(PK700.4M/PK1400.4M only)

For auto turn on/off mode, PK1400.4M amplifier offer three options: DC Offset/Rem/Audio.

REM: When auto turn on to REM, please connect the unit REM terminal to the source unit remote terminal with an 18AWG cable. This is the preferred mode.

DC Offset: If the OEM source unit has no REM signal output, You can choose DC Offset (Meanwhile, Input select switch to SPK IN mode). DC Offset can turn on/off PK series amp by detecting the 6V DC Offset from the OEM source unit terminal.

AUDIO: Audio mode can turn ON/OFF PK700.4M and PK1400.4M amp by detecting the audio signal from source unit. Note: If the volume is too Low, The amp may fail to turn on. So please check if the source unit volume is properly set.

19. RUN

This LED will light up when amplifier works properly.

20. ALARM

The red LED will light up and will be flashing if there is a fault presented to the amplifier. Please disconnect the amplifier and resolve the fault before reconnecting the amplifier.

21. Limit Indicator

This LED will light up when output clipped or amplifier get over heat. When limit indicator light up, the amplifier will hold or reduce output power to protect subwoofer and amplifier. Please turn down volume or cool down the amplifier when this indicator light up continually.

22. REMOTE

Connect the remote controller to control the Subwoofer amplifier volume from the driver seat location, for ease of adjustment during playing.

23. RCA input jacks

These RCA input jacks are for use with source units that have RCA outputs. A source unit with a minimum level of 200mV is required for proper operation. The use of high quality twisted pair cables is recommended to decrease the possibility of radiated noise entering the system.

24. Bridge In

This RCA jack receives signal from the master amplifier when this amplifier is bridged as slave. DO NOT use input jacks when the amplifier is working as slave. All the functions will be adjusted by the master amplifier.

25. Bridge Out

This RCA output send out bridge signal to another same X-series amplifier in bridging configuration. All the functions will be adjusted by the master amplifier.

CONNECTING THE AMPLIFIER

- Select cable and fuse according to the following table.

MODEL	PK600.1M	PK1000.1M	PK700.4M	PK1400.4M
CABLE	6 #	4 #	6 #	4-6 #
FUSE	80 A	120 A	80 A	100 A

- Connect the amplifiers ground cable to a close, bare metal part of the frame or chassis. Use a nut and bolt, Not a screw! The ground cable must be at least the same size as the +12Volt cable.
- Connect the remote terminal to remote output of the head unit using 16 gauge (or heavier) wire.
- Connect the fuse holder within 18" (45cm) of the car battery, and run the selected cable from this fuse to the amplifier.
- Connect all the inputs with high-quality cables. Connect Remote Control if necessary.
- Insert fuse(s) into the battery fuse holder(s).
- If using a subwoofer for 2-CH and 4-CH, bridge the channels by using the Left "+" and the Right "-" terminals.

WIRING DIAGRAM

Mono Amplifier wiring (One woofer load)

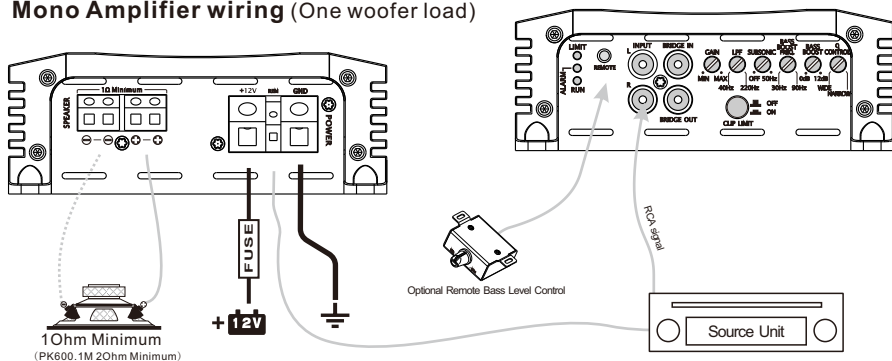

Mono Amplifier wiring (Two woofer load)

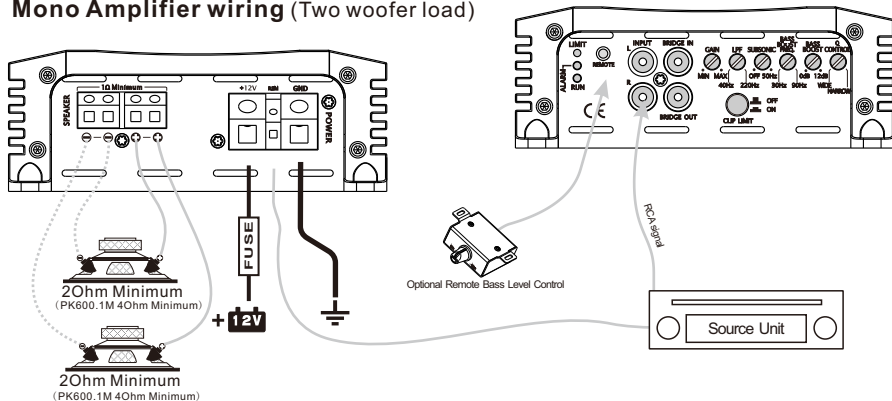

PK1000.1M Bridged mode

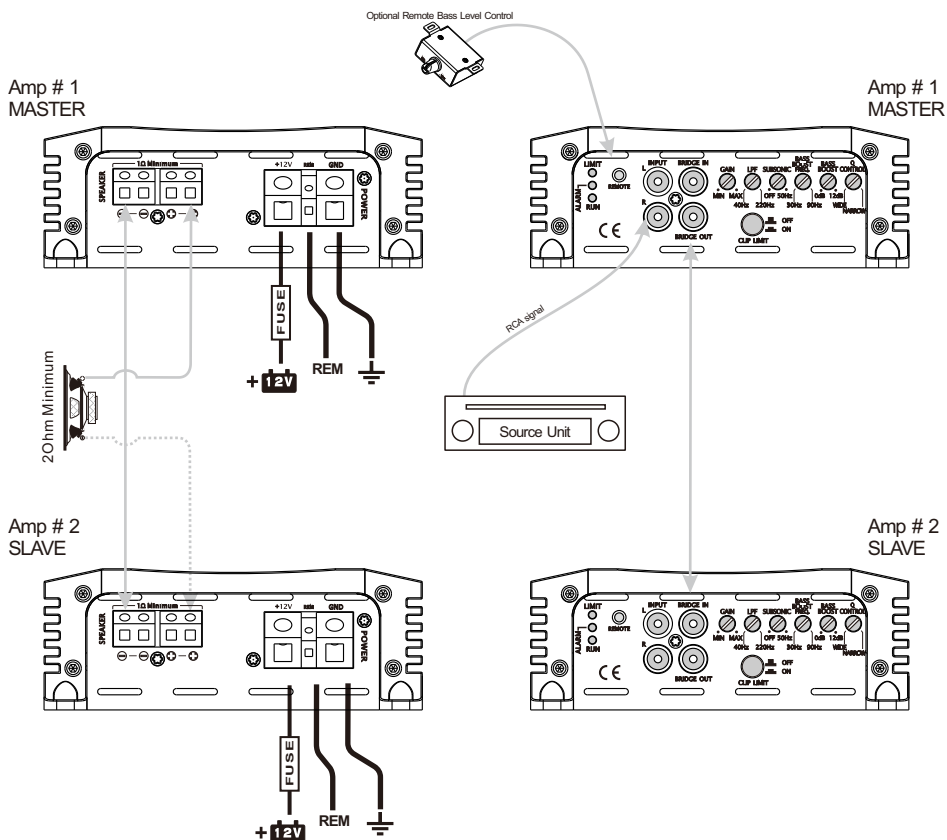

IMPORTANT

- When bridging two amplifiers you should use same model amplifiers.
- Please make sure the negative speaker terminal of two amplifiers are connected by the same gauge cables as the positive terminal being used.
- DO NOT connect any signal cables to the input RCA jacks when bridged as slave unit.
- All the functions will be disabled on slave amplifier when bridged. It will be adjusted by the master amplifier.

PK700.4M/PK1400.4M wiring (Take PK1400.4M as an example)
Four-channel mode

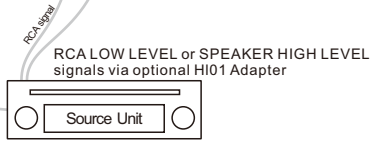
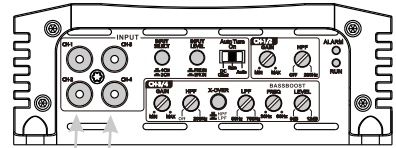
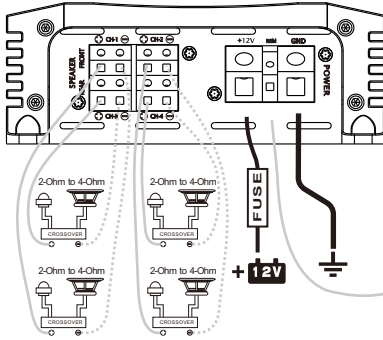

PK700.4M/PK1400.4M wiring (Take PK1400.4M as an example)
Three-channel mode

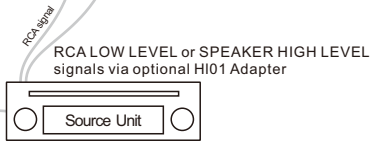
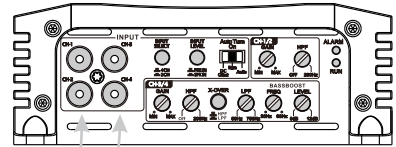
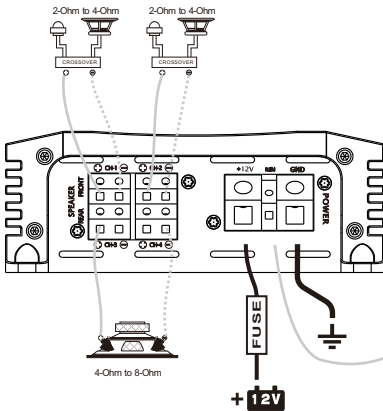

TROUBLE SHOOTING

Symptom	Possible Remedy
Amplifier will not power up	<p>Check to make sure you have a good ground connection.</p> <p>Check that there is battery power on the (+)terminal .</p> <p>Check all fuses , replace if necessary .</p> <p>Make sure that the Protection LED is not illuminated.</p>
Protection LED Comes on	<p>Check for short circuits on speaker leads .</p> <p>Check the speaker load not beyond the minimum load.</p> <p>Remove speaker lead, and reset the amplifier. If the protection LED still Comes on, then the amplifier is faulty and needs servicing .</p>
No output	<p>Check that the RCA audio cables are plugged into the proper inputs .</p> <p>Check all speakers wiring.</p> <p>Check the headunit output and the amplifier level setting.</p>
Low output	<p>Reset the level Control.</p> <p>Check the Crossover Control settings .</p>
High hiss in The speakers	<p>Check the RCA cable is not shorted to power ground at amplifier side.</p> <p>Check the amplifier grounding.</p>
Distorted sound	<p>Check that the Input level control is set to match the signal level of the head unit.</p> <p>Always try to set the Input level as low as possible.</p> <p>Check that all crossover frequencies are properly set.</p> <p>Check for short circuits on the speaker leads.</p>
Amplifier gets Very hot	<p>Check that the minimum load impedance for the amplifier model is correct.</p> <p>Check that there is good air circulation around the amplifier. In some applications , It may be necessary to add an external cooling fan.</p>

If your amplifier is still malfunction after checking through the troubleshooting section, please contact our authorized SOUNDMAGUS dealer.

SPECIFICATIONS

Model	PK600. 1M	PK1000. 1M	PK700.4M	PK1400.4M
RMS Power at 14.4V (THD < 1%)				
1Ohm Load	N/A	1000W x 1	N/A	N/A
2Ohm Load	600W x 1	650W x 1	170W x 4	300W x 4
4Ohm Load	400W x 1	400W x 1	100W x 4	400W x 4
Bridged 4Ohm Load	N/A	N/A	360W x 2	800W x 2
Features				
Input Level	0. 2~5V	0. 2~5V	PRE IN:0.2~5V SPK IN:0. 4~10V	
Frequency Response	15Hz ~ 220Hz	15Hz~220Hz	20~20KHz	20~20KHz
X-over Type	LPF/Subsonic	LPF / Subsonic	LPF/FULL/ HPF	LPF / HPF
LPF	40Hz ~ 220Hz	40Hz~220Hz	50~750Hz	50~750Hz
Subsonic/HPF	OFF ~ 50Hz	OFF~50Hz	50~750Hz	10~200Hz
Bass Boost Frequency	50Hz	30Hz~90Hz	N/A	30Hz~90Hz
Bass Boost Level	0dB/6dB/12dB	0dB~12dB	N/A	0dB~12dB
Intelligent Power Management System	N/A	YES	N/A	N/A
S/N Ratio	>70dB (1W)	>70dB (1W)	>70dB (1W)	>70dB (1W)
Minimum Load	2 Ohm	1 Ohm	2 Ohm	
Voltage Range	8. 3V ~ 16V	8. 3V ~16V	8. 3V ~16V	
Bass Remote	YES	YES	N/A	
Components & PCB	SMD Parts / Double side FR-4 PCB			
DIMENSION				
Height (mm)	56			
Width (mm)	150			
Length (mm)	238	355	275	345

型号	PK600. 1M	PK1000. 1M	PK700.4M	PK1400.4M
14. 4V额定功率 (失真度<1%)				
1欧姆负载	否	1000W x 1	否	否
2欧姆负载	600W x 1	650W x 1	170W x 4	300W x 4
4欧姆负载	400W x 1	400W x 1	100W x 4	400W x 4
桥接4欧姆负载	否	否	360W x 2	800W x 2
产品特征				
输入信号电平	0. 2~5V	0. 2~5V	RCA输入:0.2~5V 扬声器输入:0.4~10V	
频率响应	15Hz ~ 220Hz	15Hz~220Hz	20~20KHz	20~20KHz
滤波器类型	低通/高通	低通/次低通	低通/全通/高通	低通/高通
低通频率	40Hz ~ 220Hz	40Hz~220Hz	50~750Hz	50~750Hz
次低通频率/高通频率	OFF ~ 50Hz	OFF~50Hz	50~750Hz	10~200Hz
低音增益调节频率	50Hz	30Hz~90Hz	否	30Hz~90Hz
低音增益调节	0dB/6dB/12dB	0dB~12dB	否	0dB~12dB
智能功率管理系统	N/A	YES	否	否
信噪比	>70dB (1W)	>70dB (1W)	>70dB (1W)	>70dB (1W)
最小负载	2 欧姆	1 欧姆	2 欧姆	
电压范围	8. 3V ~ 16V	8. 3V ~ 16V	8. 3V ~ 16V	
可选遥控	是	是	否	
零部件 & PCB	SMT & 双面电路板			
产品尺寸				
高度 (毫米)	56			
宽度 (毫米)	150			
长度 (毫米)	238	355	275	345

故障对策

故障

检测方法

<p>电源指示灯不亮</p> <p>检查电源线和接地线是否正确连接</p> <p>检查开关控制线是否和机头的首端设备正确连接</p> <p>检查所有的保险管是否损坏</p> <p>检查蓄电池电压是否过低</p>	<p>电源指示灯亮，但仍没有声音</p> <p>检查音频信号源的重置控制器</p> <p>检查功放的电平调节钮(GAIN)</p> <p>检查音频信号线及其连接情况</p> <p>检查扬声器是否损坏及其连接线是否正确</p>	<p>一个声道不工作</p> <p>检查此声道的音频信号线的连接情况</p> <p>检查此声道扬声器的输出端子的连接情况</p> <p>检查音频声道平衡调节器是否调整到中间</p> <p>检测此声道对应的扬声器是否损坏</p>	<p>功放不停的开关</p> <p>检查功放接地线是否接触良好</p> <p>检查蓄电池接线端子和电源端子是否接触良好</p> <p>检查蓄电池电压是否过低</p> <p>遥控开关机的连接线接触不良</p>	<p>音色失真</p> <p>检查音源设备音量是否过大，超出了本机或扬声器的正常工作范围</p> <p>检查功放输入信号电平GAIN旋钮是否在合适的位置</p> <p>检查扬声器是否已损坏</p>	<p>功放处于保护状态</p> <p>检查功放扬声器输出端是否有短路，扬声器是否损坏</p> <p>检查功放温度是否过高</p> <p>检查扬声器阻抗是否正确</p> <p>检查蓄电池电压是否过低</p>
---	--	---	---	--	--

若有其他问题请联系“圣美歌指定经销商”或登陆圣美歌官方网站www.soundmagus.cn(中文域名“圣美歌·中国”)获得相关技术支持。

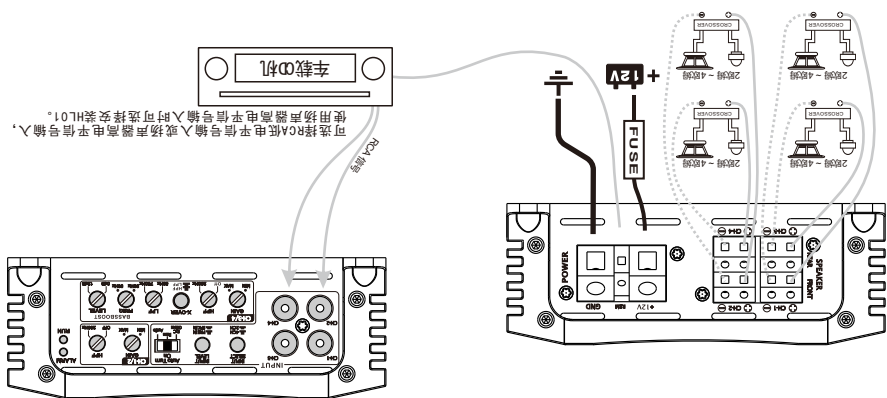

4声道连接模式
PK700.4M/PK1400.4M连接图(以PK1400.4M为例)

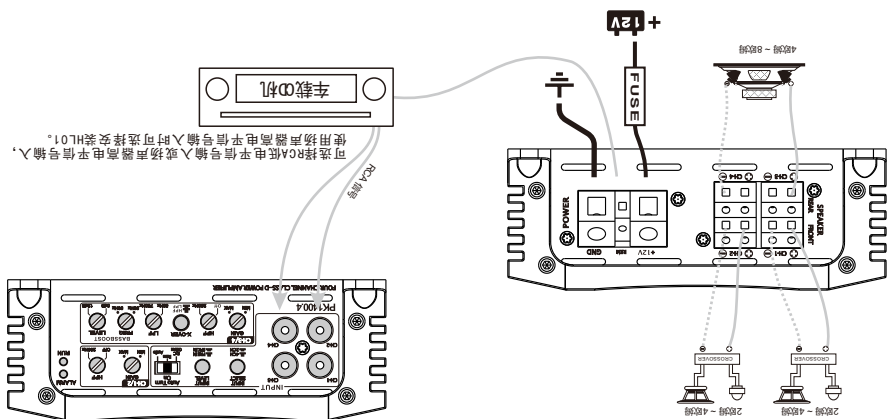

3声道连接模式
PK700.4M/PK1400.4M连接图(以PK1400.4M为例)

PK1000.1M 桥接模式

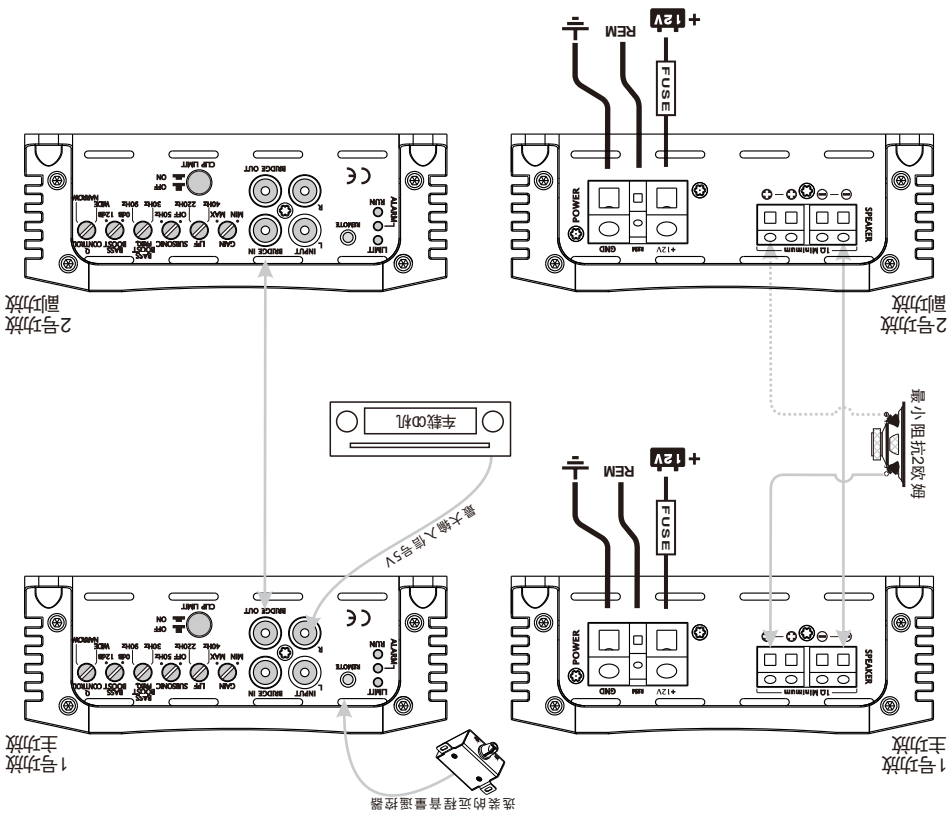

双功放桥接注意事项：

- 双功放桥接时，需使用两台相同型号的功放。
- 请务必使用与扬声器接线相同规格的线材直接连接两台功放的扬声器负载输出端子。
- 当功放作为副机时，不要再连接输入信号到其RCA输入端口，只需要用单条RCA信号线连接主功放的BRIDGE OUT和副功放的BRIDGE IN即可。
- 当功放作为副机时，所有的信号调节以及遥控功能将失效，副功放将完全受控于主功放。

当两台功放桥接时，主功放通过这个BRIDGE OUT插孔输出给副功放同步控制信号，副功放使用BRIDGE IN 插孔接收来自主功放的此信号后，副功放的所有调节功能将全部失效，副功放完全被主功放所控制。(请参考双功放桥接连接图)

25 BRIDGE OUT 双功放桥接时主功放信号输出端子

圣美数字低音功放具有双功放桥接的功能，您可以把两台同型号的功放桥接以推动更大功率的扬声器。当两台功放桥接时有主功放和副功放之分，副功放通过此BRIDGE IN插孔来接收来自主功放的同步控制信号，以实现全部功能。此时请不要再使用副功放的其他RCA信号输入插孔，副功放的所有调节功能也将全部失效，副功放完全被主功放控制。(请参考双功放桥接连接图)

24 BRIDGE IN 双功放桥接时副功放信号输入端子

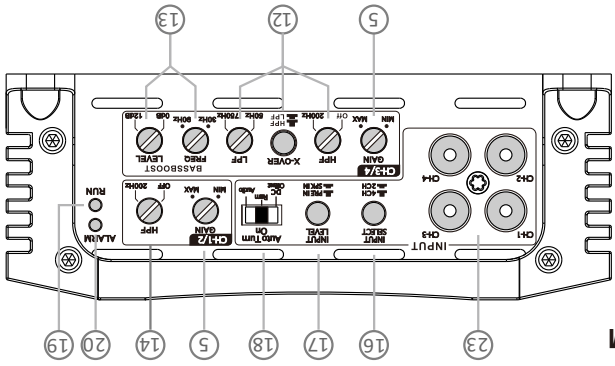

PK1400.4M

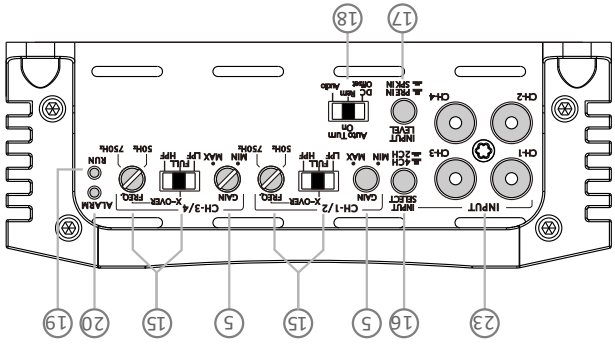

PK700.4M

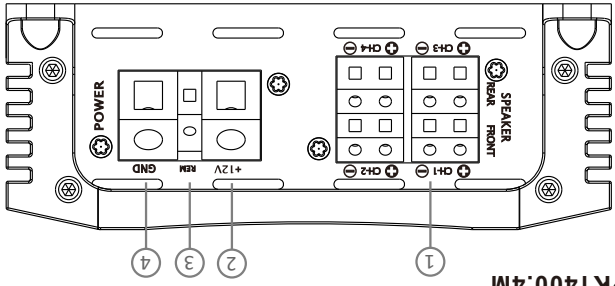

PK700.4M/PK1400.4M

14 高通频率调节

这个旋钮用于调节高通截止频率。高通功能可以滤除扬声器无法播放的过低频率，使扬声器工作在最佳状态。当此旋钮定时旋转到OFF位置时，此滤波器将关闭，低频率信号将不被滤除。

15 高通/全通/低通滤波器模式调节开关及旋钮

这个旋钮及开关的组合用于调整功放的工作频率范围。当开关设定在LPF(低通)或HPF(高通)时，相应的滤波器工作频率就可以通过旋钮在50Hz至750Hz之间进行设定。当推动低音扬声器时，开关应设置在LPF模式；当推动小口径全频扬声器或中音扬声器时，开关应设置在HPF模式；当推动较大口径的全频扬声器时可以设置在FULL(全通)模式。当开关选定在FULL模式时，滤波器频率调节旋钮将没有作用。

16 单组/双组RCA输入信号切换开关(适用于PK700.4M/PK1400.4M)

当此按钮设置为4CH模式时，功放的A组和B组RCA输入端需要分别输入立体声信号，功放的4个声道将独立工作。当此按钮关设置为2CH模式时，功放只需输入A组的RCA立体声信号，B组即接入A与A组相同的信号。此功能便于连接只有一组RCA信号输出的音源设备。

17 高/低电平信号输入切换开关(适用于PK700.4M/PK1400.4M)

功放有两种不同的输入灵敏度，可以接收来自主机RCA输出的低电平或SPK输出的高电平立体声信号。

当此按钮切换为PRE IN模式时，是通过主机的C端将低电平信号输入至功放。

当此按钮切换为SPK IN模式时，是将主机扬声器输出端的高电平信号通过HL01(高/低电平转换器)来输入至功放的RCA端。

18 自动开关机控制模式选择开关(适用于PK700.4M/PK1400.4M)

PK700.4M/PK1400.4M功放提供三种开机模式给用户选择使用，分别为DC Offset/Rem/Audio模式。Rem：这是首选的开机方法。

DC Offset：如果使用原车主机，且没有REM信号输出，可以选择DC Offset(同时将Input Select开关切换为SPK IN模式)，DC Offset开机模式是检测到原车主机喇叭输出端的6V直流电压来自自动开启功放。

Audio：此模式是通过检测到来自汽车主机输出的音频信号来控制控制功放的开关。

这种自动开机方式要注意原车主机音量的设置，主机的音量大小可能会出现功放无法开启的情况。

19 工作指示灯

当功放处于开机自检状态时，此蓝色工作指示灯熄灭或闪烁，当功放自检完成进入正常工作状态时，此蓝色工作指示灯为长亮状态。

20 自检及保护状态指示灯

保护指示灯点亮时表示功放处于开机自检状态或出现故障。当出现短路、过载、过热以及欠压保护时此指示灯点亮且功放停止工作。注意：功放处于保护状态时，请及时关机并排除故障，以免造成功放损坏！如果是过载、短路引起的故障，请及时检查扬声器连接线路以及阻抗；如果是过热引起保护，请检查功放是否有良好的散热条件；如果是电压不足引起的保护，请检查电源线路以及蓄电池电压是否正常。

21 输出削波、过热限制指示灯

当功放输出削波或温度进入预警范围时，此指示灯会点亮。当工作在满功率状态时，此指示灯会闪烁。如按下CLIP LIMIT按钮，此时功放会抑制过高的失真信号。当功放温度升高到预警范围时，此灯会点亮且功放输出功率会下调，以确保功放的正常工作，此灯常时，请调低音量或改善功放散热条件。

22 音量遥控器插座

此插座用来连接可选配的圣美歌数字低音功放音量遥控器，音量遥控器可以对坐在操控方便的地方，使您可以在座位上直接控制此功放的输出音量。

23 输入信号(RCA)端子

本机采用了高性能平衡式输入电路，在确保高保真输入的同时也可以最佳的滤除汽车电流噪声，使用户彻底摆脱电流噪声的困扰。请注意：RCA端子外壳不可接地，并应尽量缩短信号线的长度。

如果您的音源设备没有RCA输出接口，可以使用圣美歌HTL系列信号适配器。

PK600.1M/PK1000.1M

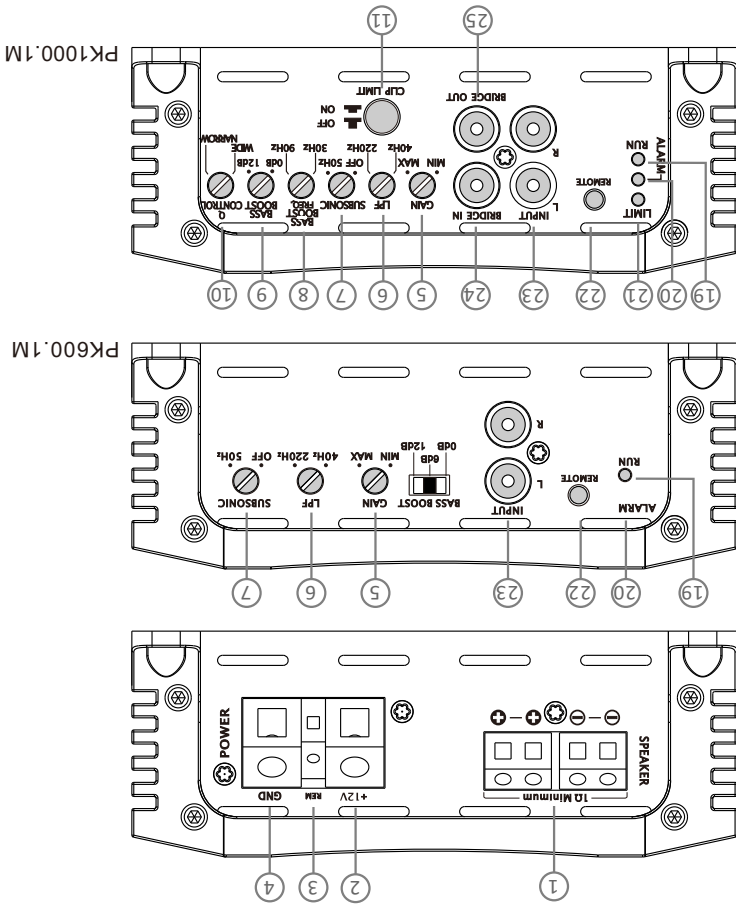

12 滤波器类型和频率控制旋钮

这是用于调节低通滤波功能的开关和旋钮。当低通开关被按下时，低通滤波功能打开，可以通过调节低通滤波按钮设定低通滤波的截止频率。此功能通常用于驱动低音扬声器。在低通模式下，高通滤波器仍然在工作，此时它可以当作次低音滤波器，无法播放的次低音信号。当低通开关被拔出时，低通滤波器停止工作，低通频率调节旋钮也不再起作用。

13 低音增强的频率和幅度

这两个旋钮配合使用可以达到完美的低音提升效果。您可以通过调整频率旋钮选择您希望提升的低音中心频率，同时通过调整低音幅度提升旋钮把这个频率点提升到希望的电平。低音频率调节范围是30~90Hz，低音幅度的提升范围则是0~12dB。低音提升功能在高通和低通模式下都是有效的。

功能简介

1 扬声器输出端子

请将扬声器的正极与功放的输出正极相接，其负极与功放的输出负极相接。请勿将扬声器连接线 & 功放表面接触，否则会损坏您的功放。我们建议采用AWG(美线标)16#或以上的扬声器专用连接线。具体连接方法详见扬声器连接图(请参考8-11页)。

2 +12V电源输入端子

用于连接12V汽车蓄电池正极端。
 注意：为确保功放有充足的电源供应，应使用专用电源线直接连接于蓄电池的正极，并在距离蓄电池正极端20厘米内串接保险丝。(电线线径及保险丝规格请参照表1)

3 遥控开关机端子

用于连接汽车CD机/音源设备的开关机控制输出信号，功放将随着CD机/音源设备的开关而开关。若使用原车配置的无开关机遥控输出的CD机时，可以选配圣美歌HTL系列适配器实现开关机同步控制功能。

4 电源接地端子

用于连接功放接地电缆，电源接地线需要稳固的连接在车体、大梁等导电良好的地方，请使用和电源线相同规格的线缆，在功放安装位置就近连接车体。请确保接地点接触良好并采取适当的抗氧化措施。

5 电平调节旋钮

本机可以输入电平为0.2V~5V的音频信号，安装调试时，需调整GAIN旋钮使功放输入电平与音源设备输出电平相匹配。(注意：电平调节旋钮不是音量调节旋钮，调整到合适的信号输入电平是完美容质的基本保证，请配合不同的CD机特性调整到合适的电平，电平过高可能会损坏扬声器，也可能产生背景噪声。)

6 LPF低通滤波器调节旋钮

从40Hz到220Hz连续可调的低通滤波器，用于调整功放的低音输出频率范围。(如：调整在120Hz则低于120Hz的低音信号可以被功放放大输出)。

7 SUBSONIC次低音滤波器调节旋钮

用于滤除人耳听不到的或扬声器无法重播的次低音频率，从而减少扬声器和功放的无效功率，也减少系统耗电。(如：SUBSONIC旋钮调整在40Hz，则低于40Hz的次低音信号将被功放滤除，不会被放大并输出给扬声器。)

8 BASSBOOST FREQ低音增强频率调节旋钮

此旋钮用于调节低音信号增强的中心频率点，您可以根据音响系统的低频特性选择30Hz~90Hz之间的任意频率点进行精确提升。(如：此旋钮调整为50Hz时，功放将以对中心点为50Hz频段信号进行提升。)配合低音增强幅度调节旋钮可以对该频段的提升幅度进行调节。

9 BASSBOOST低音增强幅度调节旋钮

此旋钮与BASSBOOST FREQ旋钮配合使用，可以将上述BASSBOOST FREQ选定的低音频率点做为中心，实现0~12dB的幅度提升。(如：前面的BASSBOOST FREQ旋钮调整为50Hz，此处的BASSBOOST旋钮调整为6dB，功放将针对以50Hz为中心的低频信号进行6dB的提升。)

10 低音增强的Q值调节旋钮

这个旋钮可以调节低音增强的频率响应宽窄特性，调到NARROW端，可以使增强的频段变窄，调到WIDE端可以使增强的频段变宽。和BASSBOOST FREQUENCY、BASSBOOST LEVEL一起使用，可以使功放和你的系统达到完美匹配的频率响应曲线。

11 削波限制按钮

削波限制功能按钮ON/OFF。打开时，功放会限制波形的削波幅度在一个较低的范围，从而尽可能的保持小的失真。

特征：

- ✓ 高效、节能型数字汽车功放
- ✓ 大功率型、紧凑型产品
- ✓ 使用由MCU控制的数字电源平台(PK700.4M/PK1400.4M)
- ✓ 高电平/低电平输入信号切换(PK700.4M/PK1400.4M)
- ✓ 自动开/机控制模式选择开关(PK700.4M/PK1400.4M)
- ✓ 大容量电解电容，全MOSFET大电流高效率数字电路
- ✓ 可调节的高通\低通滤波器、可调节的次低音滤波器
- ✓ 频率、幅度可调节的低音提升功能
- ✓ 削波限制及低音增强的Q值调节功能(PK1000.1M)
- ✓ 过载、短路、低电压、过热保护
- ✓ 无铅工艺绿色环保产品及欧盟安全认证

尊敬的用户：

感谢您购买圣美歌公司PK系列船用音频功率放大器产品，您所选择的产品融入了世界先进的设计理念和技术，它专为追求超大功率、超级震撼以及高保真音响效果的音响发烧友精心打造，具有强劲的功率输出、完美的音质表现和完善的自我保护功能。圣美歌功放很好地结合了音质优美以及功率强劲的特点，无论聆听细腻的古典音乐还是劲爆的摇滚歌曲，都能给您前所未有的音乐体验。圣美歌功放全部选用高品质器件并经过严格的质量控制体系加工而成，相信它定能带给您一段长久愉快的音乐之旅。请您到经过圣美歌公司授权的“圣美歌指定安装店”处安装本产品，我们将为您提供为期一年的免费保修服务，为正确安装和使用本产品，请您仔细阅读本使用说明书并妥善保存，以备日后参考。

SOUNDMAGUS INTERNATIONAL LIMITED

圣美歌国际（香港）有限公司

SOUNDMAGUS TECHNOLOGY CO.LTD.

深圳市圣美歌科技有限公司

<http://www.soundmagus.cn>

使用手册

PK600.1M / PK1000.1M
PK700.4M / PK1400.4M

